

## ST 3000 Smart Transmitter Series 100 Gauge Pressure Models

STG140	0 to 500 psi	0 to 35 bar	/	STG17L	0 to 3000 psi	0 to 210 bar
STG14L	0 to 500 psi	0 to 35 bar	/	STG180	0 to 6000 psi	0 to 415 bar
STG170	0 to 3000 psi	0 to 210 bar	/	STG18L	0 to 6000 psi	0 to 415 bar
STG19L	0 to 10000 psi	0 to 690 bar				

## Specification and Model Selection Guide

### Introduction

In 1983, Honeywell introduced the first Smart Pressure Transmitter—the ST 3000®. In 1989, Honeywell launched the first all digital, bi-directional protocol for smart field devices. Today, its ST 3000 Series 100 In-line Pressure Transmitters continue to bring proven “smart” technology to a wide spectrum of measurement applications. These transmitters are screwed directly onto a ½” male NPT nipple. Typical applications include high-pressure measurement in boilers, fuel feeds, and high-pressure reaction vessels in the petrochemical and hydrocarbon recovery industries – any location where accuracy and reliability are crucial to safe, economical operation. Honeywell In-line Transmitters offer the ability to be installed in a wide variety of hazardous environments for accurate repeatable pressure measurement.

All ST 3000 transmitters can provide a 4-20 mA output, Honeywell Digitally Enhanced (DE) output, HART® output, or FOUNDATION™ Fieldbus output. When digitally integrated with Honeywell’s Process Knowledge System™, EXPERION PKS™, ST 3000 instruments provide a more accurate process variable as well as advanced diagnostics.

Honeywell’s high-performance ST 3000 S100 transmitters lead the industry in:

- Accuracy
- Stability
- Reliability
- Rangeability
- Warranty

Includes Lifetime™ Transmitters:

- Accuracy = +/-0.0375%
- Stability = +/-0.01% per year
- Reliability = 470 years MTBF
- Rangeability = 400 to 1
- Lifetime Warranty = 15 years



**Figure 1**—Series 100 Gauge Pressure Transmitters feature proven piezoresistive sensor technology.

The devices provide comprehensive self-diagnostics to help users maintain high uptime, meet regulatory requirements, and attain high quality standards. S100 transmitters are ideal for critical applications, such as custody transfer of natural gas and energy and material balances, where accuracy and stability are of the utmost importance.

"Our commitment to Honeywell field instruments is based on seamless integration with our Honeywell system and the enhanced fault detection that the Honeywell DE protocol offers. Honeywell instruments also offer us a better way of ensuring database integrity over simple analog instruments. In addition, Honeywell's high-quality support has enabled us to better implement solutions to some of our more difficult problems. We have used Honeywell differential pressure smart transmitters for the past eight years. Based on their accuracy and low failure rates, we are now targeting critical flow applications that require the robustness that these transmitters bring."

DCS Systems Engineer  
International Integrated Oil Company

## Description

The ST 3000 transmitter can replace any 4 to 20 mA output transmitter in use today and operates over a standard two-wire system.

The measuring means is a piezoresistive sensor, which actually contains three sensors in one. It contains a differential pressure sensor, a temperature sensor, and a static pressure sensor.

Microprocessor-based electronics provide higher span-turndown ratio, improved temperature and pressure compensation, and improved accuracy.

The transmitter's meter body and electronics housing resist shock, vibration, corrosion, and moisture. The electronics housing contains a compartment for the single-board electronics, which is isolated from an integral junction box. The single-board electronics is replaceable and interchangeable with any other ST 3000 Series 100 or Series 900 model transmitter.

Like other Honeywell transmitters, the ST 3000 features two-way communication between the operator and the transmitter through our Smart Field Configurator (SFC). You can connect the SFC anywhere that you can access the transmitter signal lines.

The SCT 3000 Smartline<sup>®</sup> Configuration Toolkit provides an easy way to configure instruments using a personal computer. The toolkit enables configuration of devices before shipping or installation. The SCT 3000 can operate in the offline mode to configure an unlimited number of devices. The database can then be loaded downline during commissioning.

## Features

- Choice of linear or square root output conformity is a simple configuration selection.
- Direct digital integration with Experion PKS and other control systems provides local measurement accuracy to the system level without adding typical A/D and D/A converter inaccuracies.
- Unique piezoresistive sensor automatically compensates input for temperature and static pressure. Added "smart" features include configuring lower and upper range values, simulating accurate analog output, and selecting preprogrammed engineering units for display.
- Smart transmitter capabilities with local or remote interfacing means significant manpower efficiency improvements in commissioning, start-up, and ongoing maintenance functions.

Specifications

Operating Conditions – All Models

Parameter	Reference Condition		Rated Condition		Operative Limits		Transportation and Storage	
	°C	°F	°C	°F	°C	°F	°C	°F
Ambient Temperature	25±1	77±2	-40 to 85	-40 to 185	-40 to 93	-40 to 200	-55 to 125	-67 to 257
Meter Body Temperature	25±1	77±2	-40 to 110*	-40 to 230*	-40 to 125	-40 to 257	-55 to 125	-67 to 257
Humidity %RH	10 to 55		0 to 100		0 to 100		0 to 100	
Overpressure								
STG140, 14L psi	0		750		750			
bar	0		50		50			
STG170, 17L psi	0		4500		4500			
bar	0		310		310			
STG180, 18L psi	0		9000		9000			
bar	0		620		620			
STG19L psi	0		15000		15000			
bar	0		1034		1034			
Vacuum Region - Minimum Pressure								
mmHg absolute	atmospheric		25		2 (short term **)			
inH <sub>2</sub> O absolute	atmospheric		13		1 (short term **)			
Supply Voltage, Current, and Load Resistance	<b>Voltage Range:</b> 10.8 to 42.4 Vdc at terminals <b>Current Range:</b> 3.0 to 21.8 mA <b>Load Resistance:</b> 0 to 1440 ohms (as shown in Figure 2)							

\* For CTFE fill fluid the rating is -15 to 110 °C (5 to 230°F)

\*\* Short term equals 2 hours at 70°C (158 °F)

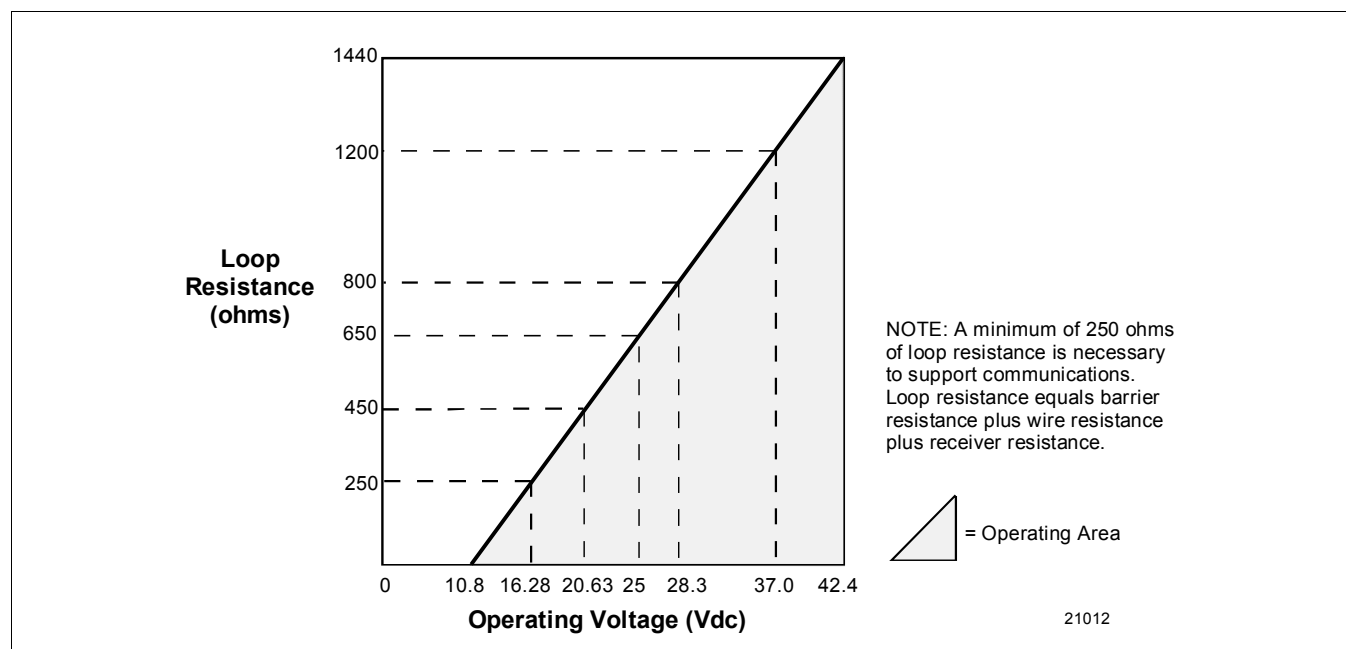


Figure 2 - Supply voltage and loop resistance chart.

**Performance Under Rated Conditions\* - Models STG140 & 14L (0 to 500 psi)**

Parameter	Description
Upper Range Limit	psi: 500      bar: 35
Minimum Span	psi: 5      bar: 0.35
Turndown Ratio	100 to 1
Zero Elevation and Suppression	No limit except minimum span from absolute 0 (zero) to +100% URL. Specifications valid over this range.
<b>Accuracy</b> (Reference – Includes combined effects of linearity, hysteresis, and repeatability) <ul style="list-style-type: none"> <li>• Accuracy includes residual error after averaging successive readings.</li> <li>• For FOUNDATION Fieldbus use Digital Mode specifications. For HART use Analog Mode specifications.</li> </ul>	<p><b>In Analog Mode:</b> ±0.075% of calibrated span or upper range value (URV), whichever is greater, terminal based.</p> <p>For URV calibrated below reference point (20 psi), accuracy equals:</p> $\pm 0.025 + 0.05 \left( \frac{20 \text{ psi}}{\text{span psi}} \right) \text{ or } \pm 0.025 + 0.05 \left( \frac{1.4 \text{ bar}}{\text{span bar}} \right) \text{ in } \% \text{ span}$ <p>* For High Accuracy (HA) option: +/- 0.0375% of calibrated span or upper range value (URV), whichever is greater, terminal based.</p> <p><b>In Digital Mode:</b> ±0.0625% of calibrated span or upper range value (URV), whichever is greater, terminal based.</p> <p>For URV calibrated below reference point (20 psi), accuracy equals:</p> $\pm 0.0125 + 0.05 \left( \frac{20 \text{ psi}}{\text{span psi}} \right) \text{ or } \pm 0.0125 + 0.05 \left( \frac{1.4 \text{ bar}}{\text{span bar}} \right) \text{ in } \% \text{ span}$ <p>* For High Accuracy (HA) option: +/- 0.035% of calibrated span or upper range value (URV), whichever is greater, terminal based</p>
Zero Temperature Effect per 28°C (50°F)	<p><b>In Analog Mode:</b> ±0.0625% of span.</p> <p>For URV below reference point of 50 psi for model STG140 or 75 psi for model STG14L, effect equals:</p> $\pm 0.0125 + 0.05 \left( \frac{50 \text{ psi}}{\text{span psi}} \right) \text{ or } \pm 0.0125 + 0.05 \left( \frac{3.5 \text{ bar}}{\text{span bar}} \right) \text{ in } \% \text{ span}$ <p><b>OR</b></p> $\pm 0.0125 + 0.05 \left( \frac{75 \text{ psi}}{\text{span psi}} \right) \text{ or } \pm 0.0125 + 0.05 \left( \frac{5.25 \text{ bar}}{\text{span bar}} \right) \text{ in } \% \text{ span}$ <p><b>In Digital Mode:</b> ±0.05% of span.</p> <p>For URV below reference point of 50 psi for model STG140 or 75 psi for model STG14L, effect equals:</p> $\pm 0.05 \left( \frac{50 \text{ psi}}{\text{span psi}} \right) \text{ or } \pm 0.05 \left( \frac{3.5 \text{ bar}}{\text{span bar}} \right) \text{ in } \% \text{ span}$ <p><b>OR</b></p> $\pm 0.05 \left( \frac{75 \text{ psi}}{\text{span psi}} \right) \text{ or } \pm 0.05 \left( \frac{5.25 \text{ bar}}{\text{span bar}} \right) \text{ in } \% \text{ span}$
Combined Zero and Span Temperature Effect per 28°C (50°F)	<p><b>In Analog Mode:</b> ±0.10% of span.</p> <p>For URV below reference point of 50 psi for model STG140 or 75 psi for model STG14L, effect equals:</p> $\pm 0.05 + 0.05 \left( \frac{50 \text{ psi}}{\text{span psi}} \right) \text{ or } \pm 0.05 + 0.05 \left( \frac{3.5 \text{ bar}}{\text{span bar}} \right) \text{ in } \% \text{ span}$ <p><b>OR</b></p> $\pm 0.05 + 0.05 \left( \frac{75 \text{ psi}}{\text{span psi}} \right) \text{ or } \pm 0.05 + 0.05 \left( \frac{5.25 \text{ bar}}{\text{span bar}} \right) \text{ in } \% \text{ span}$ <p><b>In Digital Mode:</b> ±0.075% of span.</p> <p>For URV below reference point of 50 psi for model STG140 or 75 psi for model STG14L, effect equals:</p> $\pm 0.025 + 0.05 \left( \frac{50 \text{ psi}}{\text{span psi}} \right) \text{ or } \pm 0.025 + 0.05 \left( \frac{3.5 \text{ bar}}{\text{span bar}} \right) \text{ in } \% \text{ span}$ <p><b>OR</b></p> $\pm 0.025 + 0.05 \left( \frac{75 \text{ psi}}{\text{span psi}} \right) \text{ or } \pm 0.025 + 0.05 \left( \frac{5.25 \text{ bar}}{\text{span bar}} \right) \text{ in } \% \text{ span}$
Stability	±0.015% of URL per year for lifetime

\* Performance specifications are based on reference conditions of 25°C (77°F), 10 to 55% RH, and 316 Stainless Steel barrier diaphragm.

**Performance Under Rated Conditions\* - Models STG170 & 17L (0 to 3000 psi)**

Parameter	Description
<b>Upper Range Limit</b>	<b>psi:</b> 3000 <b>bar:</b> 210
<b>Minimum Span</b>	<b>psi:</b> 100 <b>bar:</b> 7
<b>Turndown Ratio</b>	30 to 1
<b>Zero Elevation and Suppression</b>	No limit except minimum span from absolute 0 (zero) to +100% URL. Specifications valid over this range.
<p><b>Accuracy</b> (Reference – Includes combined effects of linearity, hysteresis, and repeatability)</p> <ul style="list-style-type: none"> <li>• Accuracy includes residual error after averaging successive readings.</li> <li>• For FOUNDATION Fieldbus use Digital Mode specifications. For HART use Analog Mode specifications.</li> </ul>	<p><b>In Analog Mode:</b> ±0.075% of calibrated span or upper range value (URV), whichever is greater, terminal based. For URV calibrated below reference point (750 psi), accuracy equals:</p> $\pm 0.025 + 0.05 \left( \frac{750 \text{ psi}}{\text{span psi}} \right) \text{ or } \pm 0.025 + 0.05 \left( \frac{52 \text{ bar}}{\text{span bar}} \right) \text{ in } \% \text{ span}$ <p><b>In Digital Mode:</b> ±0.0625% of calibrated span or upper range value (URV), whichever is greater, terminal based. For URV calibrated below reference point (750 psi), accuracy equals:</p> $\pm 0.0125 + 0.05 \left( \frac{750 \text{ psi}}{\text{span psi}} \right) \text{ or } \pm 0.0125 + 0.05 \left( \frac{52 \text{ bar}}{\text{span bar}} \right) \text{ in } \% \text{ span}$
<b>Zero Temperature Effect per 28°C (50°F)</b>	<p><b>In Analog Mode:</b> ±0.1125% of span. For URV below reference point (500 psi), effect equals:</p> $\pm 0.0125 + 0.10 \left( \frac{500 \text{ psi}}{\text{span psi}} \right) \text{ or } \pm 0.0125 + 0.10 \left( \frac{35 \text{ bar}}{\text{span bar}} \right) \text{ in } \% \text{ span}$ <p><b>In Digital Mode:</b> ±0.10% of span. For URV below reference point (500 psi), effect equals:</p> $\pm 0.10 \left( \frac{500 \text{ psi}}{\text{span psi}} \right) \text{ or } \pm 0.10 \left( \frac{35 \text{ bar}}{\text{span bar}} \right) \text{ in } \% \text{ span}$
<b>Combined Zero and Span Temperature Effect per 28°C (50°F)</b>	<p><b>In Analog Mode:</b> ±0.175% of span. For URV below reference point (500 psi), effect equals:</p> $\pm 0.075 + 0.10 \left( \frac{500 \text{ psi}}{\text{span psi}} \right) \text{ or } \pm 0.075 + 0.10 \left( \frac{35 \text{ bar}}{\text{span bar}} \right) \text{ in } \% \text{ span}$ <p><b>In Digital Mode:</b> ±0.15% of span. For URV below reference point (500 psi), effect equals:</p> $\pm 0.05 + 0.10 \left( \frac{500 \text{ psi}}{\text{span psi}} \right) \text{ or } \pm 0.05 + 0.10 \left( \frac{35 \text{ bar}}{\text{span bar}} \right) \text{ in } \% \text{ span}$
<b>Stability</b>	±0.03% of per year

\* Performance specifications are based on reference conditions of 25°C (77°F), 10 to 55% RH, and 316 Stainless Steel barrier diaphragm.

**Performance Under Rated Conditions\* - Models STG180 & 18L (0 to 6000 psi)**

Parameter	Description
<b>Upper Range Limit</b>	<b>psi:</b> 6000 <b>bar:</b> 415
<b>Minimum Span</b>	<b>psi:</b> 100 <b>bar:</b> 7
<b>Turndown Ratio</b>	60 to 1
<b>Zero Elevation and Suppression</b>	No limit except minimum span from absolute 0 (zero) to +100% URL. Specifications valid over this range.
<p><b>Accuracy</b> (Reference – Includes combined effects of linearity, hysteresis, and repeatability)</p> <ul style="list-style-type: none"> <li>• Accuracy includes residual error after averaging successive readings.</li> <li>• For FOUNDATION Fieldbus use Digital Mode specifications. For HART use Analog Mode specifications.</li> </ul>	<p><b>In Analog Mode:</b> ±0.075% of calibrated span or upper range value (URV), whichever is greater, terminal based. For URV calibrated below reference point (1500 psi), accuracy equals: ±0.025 + 0.05 <math>\left(\frac{1500 \text{ psi}}{\text{span psi}}\right)</math> or ±0.025 + 0.05 <math>\left(\frac{104 \text{ bar}}{\text{span bar}}\right)</math> in % span</p> <p><b>In Digital Mode:</b> ±0.0625% of calibrated span or upper range value (URV), whichever is greater, terminal based. For URV calibrated below reference point (1000 psi), accuracy equals: ±0.0125 + 0.05 <math>\left(\frac{1500 \text{ psi}}{\text{span psi}}\right)</math> or ±0.0125 + 0.05 <math>\left(\frac{104 \text{ bar}}{\text{span bar}}\right)</math> in % span</p>
<b>Zero Temperature Effect per 28°C (50°F)</b>	<p><b>In Analog Mode:</b> ±0.1125% of span. For URV below reference point (1000 psi), effect equals: ±0.0125 + 0.10 <math>\left(\frac{1000 \text{ psi}}{\text{span psi}}\right)</math> or ±0.0125 + 0.10 <math>\left(\frac{70 \text{ bar}}{\text{span bar}}\right)</math> in % span</p> <p><b>In Digital Mode:</b> ±0.10% of span. . For URV below reference point (1000 psi), effect equals: ±0.10 <math>\left(\frac{1000 \text{ psi}}{\text{span psi}}\right)</math> or ±0.10 <math>\left(\frac{70 \text{ bar}}{\text{span bar}}\right)</math> in % span</p>
<b>Combined Zero and Span Temperature Effect per 28°C (50°F)</b>	<p><b>In Analog Mode:</b> ±0.175% of span. For URV below reference point (1000 psi), effect equals: ±0.075 + 0.10 <math>\left(\frac{1000 \text{ psi}}{\text{span psi}}\right)</math> or ±0.075 + 0.10 <math>\left(\frac{70 \text{ bar}}{\text{span bar}}\right)</math> in % span</p> <p><b>In Digital Mode:</b> ±0.15% of span. . For URV below reference point (1000 psi), effect equals: ±0.05 + 0.10 <math>\left(\frac{1000 \text{ psi}}{\text{span psi}}\right)</math> or ±0.05 + 0.10 <math>\left(\frac{70 \text{ bar}}{\text{span bar}}\right)</math> in % span</p>
<b>Stability</b>	±0.03% of per year

\* Performance specifications are based on reference conditions of 25°C (77°F), 10 to 55% RH, and 316 Stainless Steel barrier diaphragm.

**Performance Under Rated Conditions\* - Models STG19L (0 to 10000 psi)**

Parameter	Description
<b>Upper Range Limit</b>	<b>psi:</b> 10000 <b>bar:</b> 690
<b>Minimum Span</b>	<b>psi:</b> 500 <b>bar:</b> 35
<b>Turndown Ratio</b>	20 to 1
<b>Zero Elevation and Suppression</b>	No limit except minimum span from absolute 0 (zero) to +100% URL. Specifications valid over this range.
<p><b>Accuracy</b> (Reference – Includes combined effects of linearity, hysteresis, and repeatability)</p> <ul style="list-style-type: none"> <li>• Accuracy includes residual error after averaging successive readings.</li> <li>• For FOUNDATION Fieldbus use Digital Mode specifications. For HART use Analog Mode specifications.</li> </ul>	<p><b>In Analog Mode:</b> ±0.075% of calibrated span or upper range value (URV), whichever is greater, terminal based. For URV calibrated below reference point (2500 psi), accuracy equals:</p> $\pm 0.025 + 0.10 \left( \frac{2500 \text{ psi}}{\text{span psi}} \right) \text{ or } \pm 0.025 + 0.10 \left( \frac{172 \text{ bar}}{\text{span bar}} \right) \text{ in } \% \text{ span}$ <p><b>In Digital Mode:</b> ±0.0625% of calibrated span or upper range value (URV), whichever is greater, terminal based. For URV calibrated below reference point (2500 psi), accuracy equals:</p> $\pm 0.0125 + 0.10 \left( \frac{2500 \text{ psi}}{\text{span psi}} \right) \text{ or } \pm 0.0125 + 0.10 \left( \frac{172 \text{ bar}}{\text{span bar}} \right) \text{ in } \% \text{ span}$
<b>Zero Temperature Effect per 28°C (50°F)</b>	<p><b>In Analog Mode:</b> ±0.1125% of span. For URV below reference point (2500 psi), effect equals:</p> $\pm 0.0125 + 0.10 \left( \frac{2500 \text{ psi}}{\text{span psi}} \right) \text{ or } \pm 0.0125 + 0.10 \left( \frac{172 \text{ bar}}{\text{span bar}} \right) \text{ in } \% \text{ span}$ <p><b>In Digital Mode:</b> ±0.10% of span. . For URV below reference point (2500 psi), effect equals:</p> $\pm 0.10 \left( \frac{2500 \text{ psi}}{\text{span psi}} \right) \text{ or } \pm 0.10 \left( \frac{172 \text{ bar}}{\text{span bar}} \right) \text{ in } \% \text{ span}$
<b>Combined Zero and Span Temperature Effect per 28°C (50°F)</b>	<p><b>In Analog Mode:</b> ±0.175% of span. For URV below reference point (2500 psi), effect equals:</p> $\pm 0.075 + 0.10 \left( \frac{2500 \text{ psi}}{\text{span psi}} \right) \text{ or } \pm 0.075 + 0.10 \left( \frac{172 \text{ bar}}{\text{span bar}} \right) \text{ in } \% \text{ span}$ <p><b>In Digital Mode:</b> ±0.15% of span. . For URV below reference point (2500 psi), effect equals:</p> $\pm 0.05 + 0.10 \left( \frac{2500 \text{ psi}}{\text{span psi}} \right) \text{ or } \pm 0.05 + 0.10 \left( \frac{172 \text{ bar}}{\text{span bar}} \right) \text{ in } \% \text{ span}$
<b>Stability</b>	±0.03% of per year

\* Performance specifications are based on reference conditions of 25°C (77°F), 10 to 55% RH, and 316 Stainless Steel barrier diaphragm.

### Performance Under Rated Conditions - General for all Models

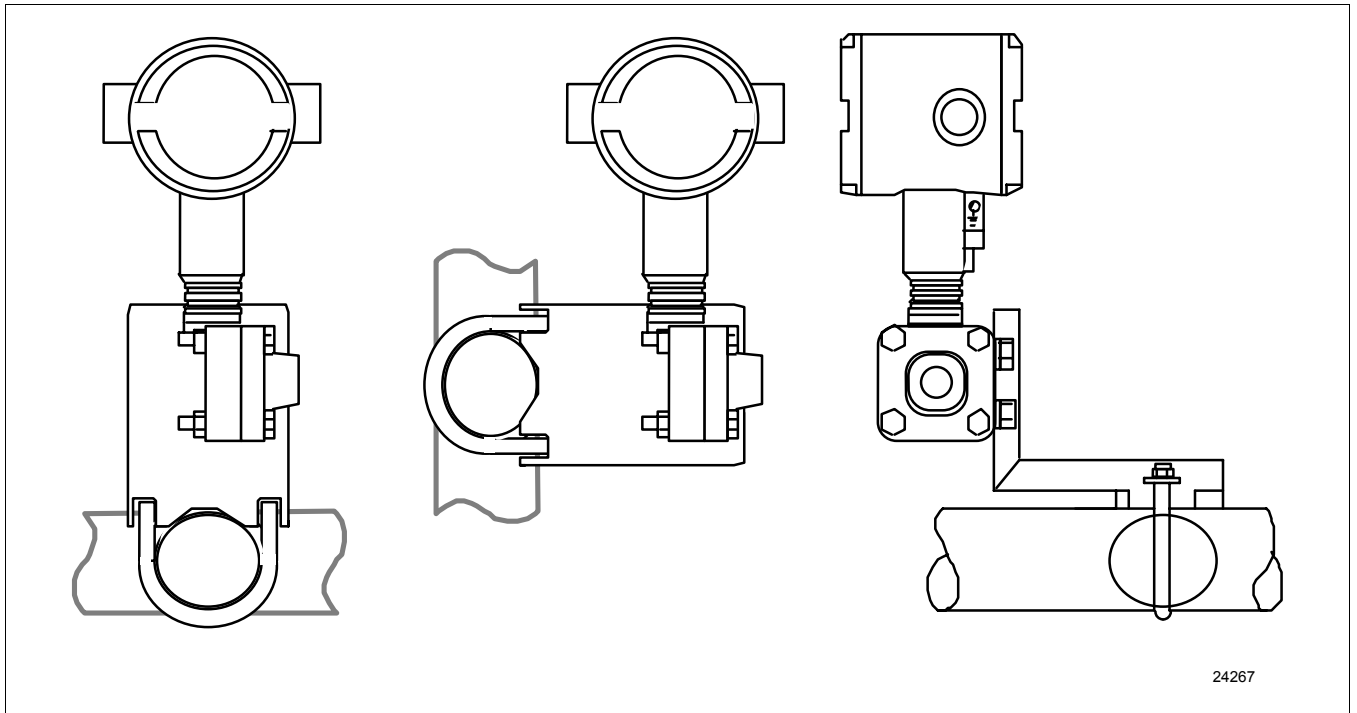
Parameter	Description
Output (two-wire)	Analog 4 to 20 mA or digital communications DE mode. Options available for FOUNDATION Fieldbus and HART protocol.
Supply Voltage Effect	0.005% span per volt.
Damping Time Constant	Adjustable from 0 to 32 seconds digital damping.
CE Conformity (Europe)	89/336/EEC, Electromagnetic Compatibility (EMC) Directive.
Lightning Protection Option (Code "LP")	Leakage Current: 10 microamps max. @ 42.4 VDC, 93°C Impulse Rating: 10/20 μ sec. 5,000 Amps (50 strikes) 10,000 Amps (20 strikes) (rise/decay) 10/1000 μ sec. 250 Amps (1000 strikes) 500 Amps (400 strikes)

### Physical and Approval Bodies

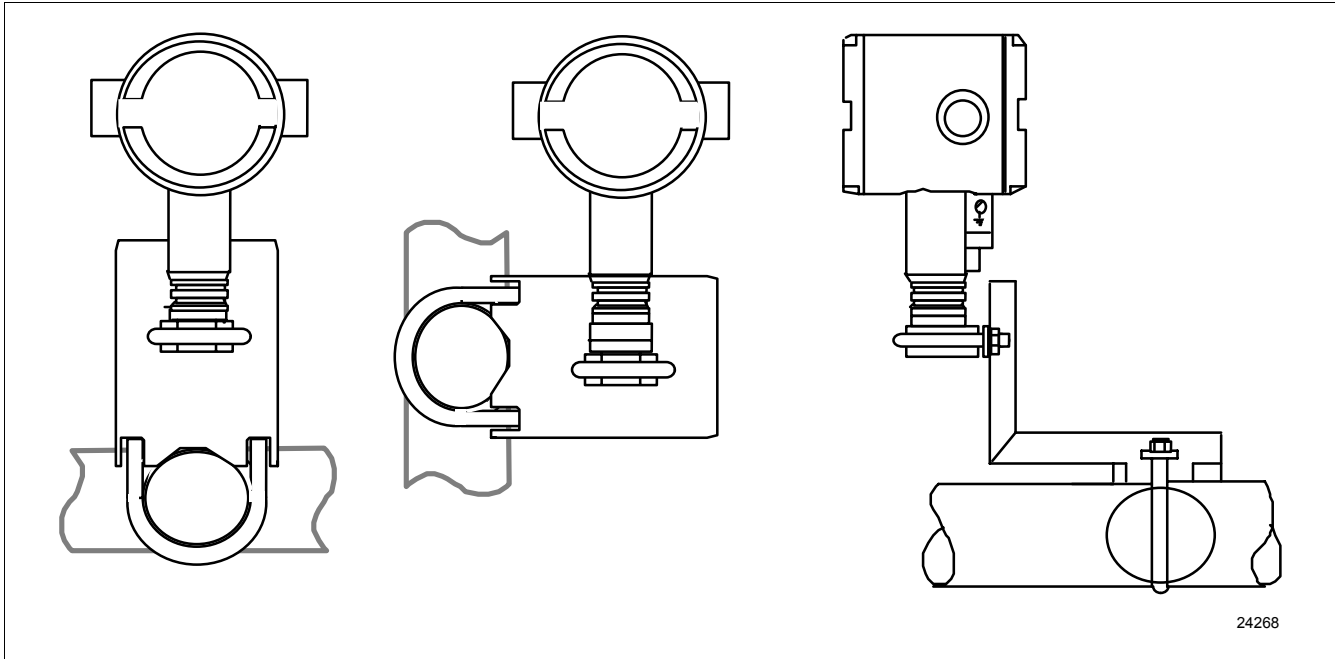
Parameter	Description
Barrier Diaphragms Material	<b>Single-Head Meter Body:</b> 316L SS, Hastelloy C-276, Monel <b>In-Line Meter Body:</b> 316L SS, Hastelloy C-276
Process Head Material	<b>Single-Head Meter Body:</b> 316 SS, Carbon Steel (Zinc-plated), Hastelloy, Monel <b>In-Line Meter Body:</b> 316L SS
Head Gaskets	Teflon is standard. Viton is available with 316L SS and Monel barrier diaphragms.
Meter Body Bolting	Carbon Steel (Zinc plated, standard) or A286 SS (NACE) bolts and 302/304 SS (NACE) nuts for heads.
Mounting Bracket	Carbon Steel (Zinc-plated) or Stainless Steel angle bracket or Carbon Steel flat bracket available.
Fill Fluid	Silicone oil or CTFE (Chlorotrifluoroethylene)
Electronic Housing	Epoxy-Polyester hybrid paint. Low Copper-Aluminum. Meets NEMA 4X (watertight) and NEMA 7 (explosion proof). Stainless Steel Optional
Process Connections	<b>Single-Head Meter Body:</b> 1/2-inch NPT, 9/16-18 Aminco, DIN (standard option) <b>In-Line Meter Body:</b> 1/2-inch NPT
Wiring	Accepts up to 16 AWG (1.5 mm diameter).
Mounting	Can be mounted in virtually any position using the standard mounting bracket. Bracket is designed to mount on 2-inch (50 mm) vertical or horizontal pipe. See Figure 3 for single-head models and Figure 4 for in-line models.
Dimensions	See Figures 5 and 6.
Net Weight	<b>With Single-Head Meter Body:</b> 10 pounds (4.5 Kg) <b>With In-Line Meter Body:</b> 3.8 pounds (1.7 Kg)
Approval Bodies - Hazardous Areas	Approved as explosion proof and intrinsically safe for use in Class I, Division 1, Groups A, B, C, D locations, and nonincendive for Class I, Division 2, Groups A, B, C, D locations. Approved EEx ia IIC T4, T5, T6 and EEx d IIC T5, T6 per ATEX standards. See attached Model Selection Guide for options.
Pressure Equipment Directive (97/23/EC)	The ST 3000 pressure transmitters listed in this Specification have no pressurized internal volume or have a pressurized internal volume rated less than 1,000 bar (14,500 psig) and/or have a maximum volume of less than 0.1 liter. Therefore, these transmitters are either; not subject to the essential requirements of the directive 97/23/EC (PED, Annex 1) and shall not have the CE mark, or the manufacturer has the free choice of a module when the CE mark is required for pressures > 200 bar (2,900 psig).

**NOTE:** Pressure transmitters that are part of safety equipment for the protection of piping (systems) or vessel(s) from exceeding allowable pressure limits, (equipment with safety functions in accordance with Pressure Equipment Directive 97/23/EC article 1, 2.1.3), require separate examination.

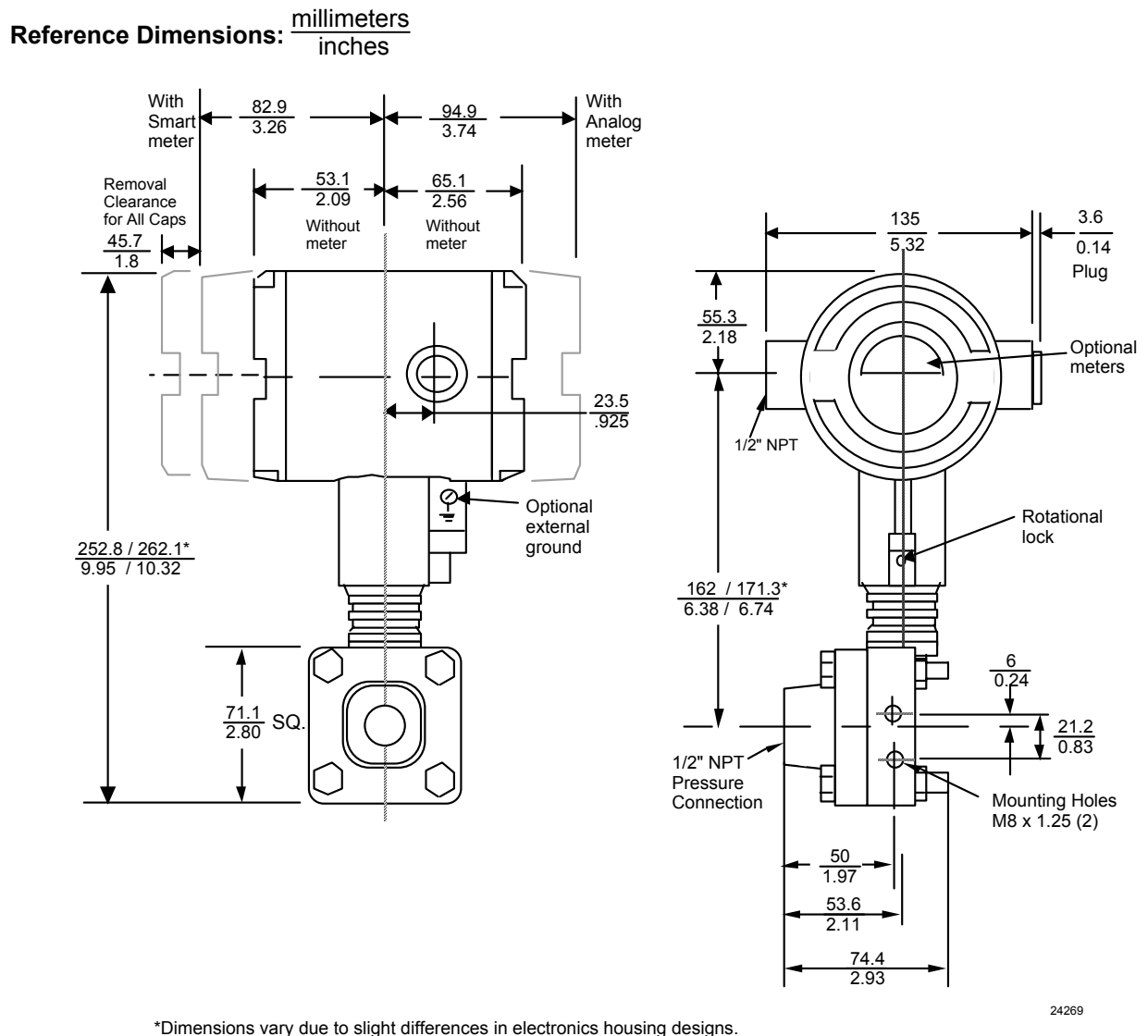




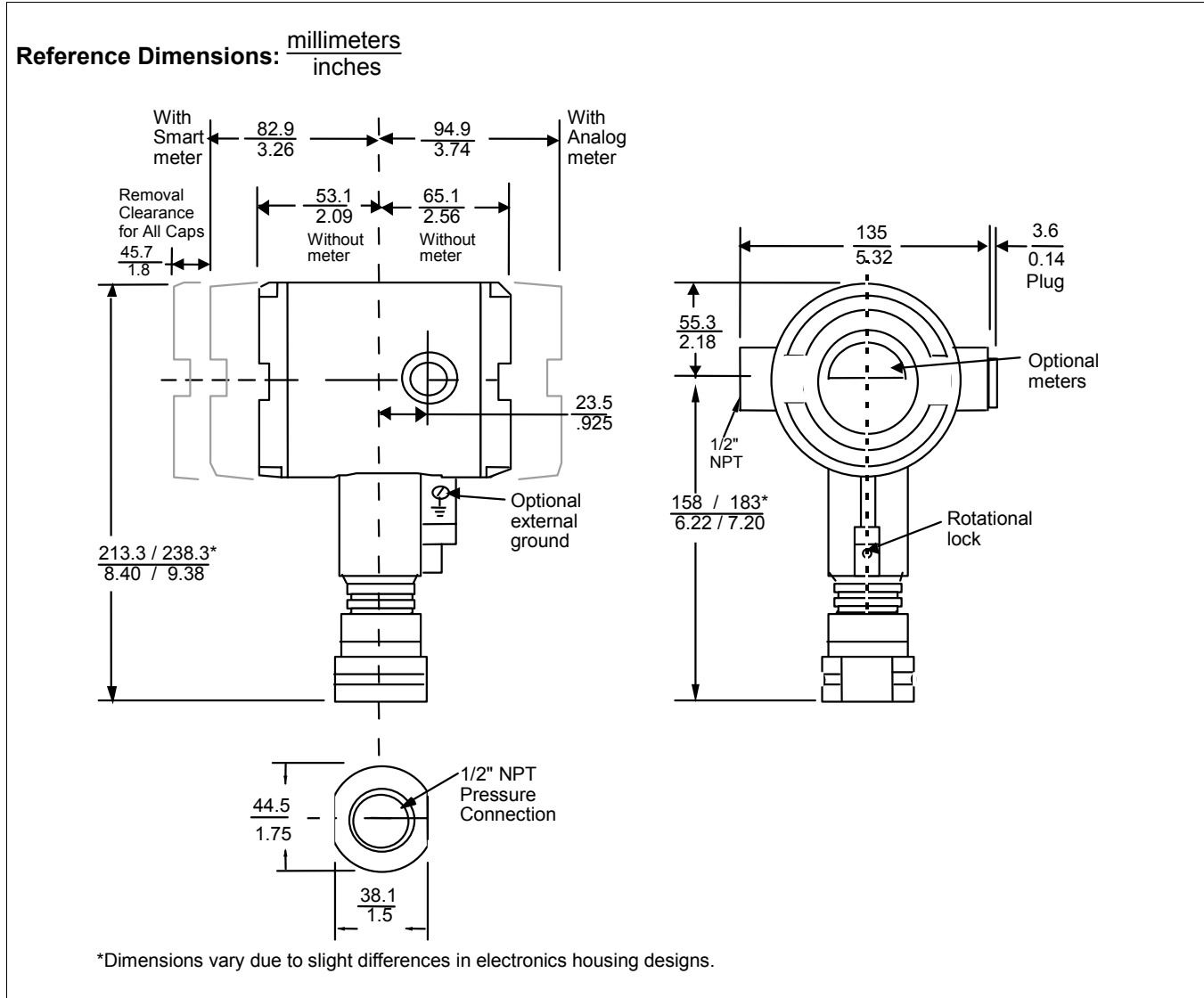
**Figure 3** - Examples of typical mounting positions for single-head models STG140, STG170, and STG180.



**Figure 4** - Examples of typical mounting positions for in-line models STG14L, STG17L, STG18L, and STG19L. Note that a mounting bracket is not required for in-line models.



**Figure 5** - Typical mounting dimensions for single-head models STG140, STG170, and STG180 for reference.



**Figure 6** - Typical mounting dimensions for in-line models STG14L, STG17L, STG18L, and STG19L for reference.

Options	Ordering Information
<p><b>Mounting Bracket</b> The angle mounting bracket is available in either zinc-plated carbon steel or stainless steel and is suitable for horizontal or vertical mounting on a two inch (50 millimeter) pipe, as well as wall mounting. An optional flat mounting bracket is also available in carbon steel for two inch (50 millimeter) pipe mounting.</p> <p><b>Indicating Meter (ME and SM Options)</b> Two integral meter options are available. An analog meter (option ME) is available with a 0 to 100% linear scale. The Smart Meter (option SM) provides an LCD display for both analog and digital output and can be configured to display pressure in pre-selected engineering units.</p> <p><b>HART Protocol Compatibility (Option HC)</b> An optional electronics module is available for the ST 3000 that provides HART Protocol compatibility. Transmitters with the HART Option are compatible with the AMS System. (Contact your AMS Supplier if an upgrade is required.)</p> <p><b>Lightning Protection (Option LP)</b> A terminal block is available with circuitry that protects the transmitter from transient surges induced by nearby lightning strikes.</p> <p><b>Lifetime Warranty (Option WL)</b> Extends limited 1-year warranty policy to 15 years for ST 3000 S100 pressure transmitters. See Honeywell Terms and Conditions.</p> <p><b>Indicator Configuration (Option CI)</b> Provides custom configuration of Smart Meters</p> <p><b>Tagging (Option TG)</b> Up to 30 characters can be added on the stainless steel nameplate mounted on the transmitter's electronics housing at no extra cost. Note that a separate nameplate on the meter body contains the serial number and body-related data. A stainless steel wired on tag with additional data of up to 4 lines of 28 characters is also available. The number of characters for tagging includes spaces.</p> <p><b>Transmitter Configuration (Option TC)</b> The factory can configure the transmitter linear/square root extraction, damping time, LRV, URV and mode (analog/digital) and enter an ID tag of up to eight characters and scratchpad information as specified.</p> <p><b>Custom Calibration and ID in Memory (Option CC)</b> The factory can calibrate any range within the scope of the transmitter's range and enter an ID tag of up to eight characters in the transmitter's memory.</p> <p><b>FOUNDATION Fieldbus (Option FF)</b> Equips transmitter with FF protocol for use in 31.25 kbit/s FF networks. See document 34-ST-03-72 for additional information on ST 3000 Fieldbus transmitters.</p> <p><b>High Accuracy</b> Extends applicable ST 3000 S100 models to +/- 0.0375% reference accuracy (analog)</p>	<p>Contact your nearest Honeywell sales office, or</p> <p>In the U.S.:</p> <p style="padding-left: 40px;">Honeywell Industrial Automation &amp; Control 16404 North Black Canyon Hwy. Phoenix, AZ 85053 1-800-288-7491</p> <p>In Canada:</p> <p style="padding-left: 40px;">The Honeywell Centre 155 Gordon Baker Rd. North York, Ontario M2H 3N7 1-800-461-0013</p> <p>In Latin America:</p> <p style="padding-left: 40px;">Honeywell Inc. 480 Sawgrass Corporate Parkway, Suite 200 Sunrise, FL 33325 (954) 845-2600</p> <p>In Europe and Africa:</p> <p style="padding-left: 40px;">Honeywell S. A. Avenue du Bourget 1 1140 Brussels, Belgium</p> <p>In Eastern Europe:</p> <p style="padding-left: 40px;">Honeywell Praha, s.r.o. Budejovicka 1 140 21 Prague 4, Czech Republic</p> <p>In the Middle East:</p> <p style="padding-left: 40px;">Honeywell Middle East Ltd. Khalifa Street, Sheikh Faisal Building Abu Dhabi, U. A. E.</p> <p>In Asia:</p> <p style="padding-left: 40px;">Honeywell Asia Pacific Inc. Honeywell Building, 17 Changi Business Park Central 1 Singapore 486073 Republic of Singapore</p> <p>In the Pacific:</p> <p style="padding-left: 40px;">Honeywell Pty Ltd. 5 Thomas Holt Drive North Ryde NSW Australia 2113 (61 2) 9353 7000</p> <p>In Japan:</p> <p style="padding-left: 40px;">Honeywell K.K. 14-6 Shibaura 1-chrome Minato-ku, Tokyo, Japan 105-0023</p> <p>Or, visit Honeywell on the World Wide Web at: <a href="http://www.honeywell.com">http://www.honeywell.com</a></p>
<p><i>Specifications are subject to change without notice</i></p>	

**Model Selection Guide (34-ST-16-03)**

Model Selection Guide  
34-ST-16-03 Issue 31

Honeywell Confidential & Proprietary

**Instructions**

- Select the desired Key Number. The arrow to the right marks the selection available.
- Make one selection from each Table I and II using the column below the proper arrow.
- Select as many Table III options as desired (if no options or approvals are desired, specify 9X).  
A (\*) denotes unrestricted availability. A letter denotes restricted availability.  
Restrictions follow Table IV.

Key Number      I      II      III (Optional)      IV  
 [ ] - [ ] - [ ] - [ ] + [ ]

KEY NUMBER		Selection	Availability			
Design	Span					
Gage Pressure	Head	0-5 to 0-500 psi/0-0.34 to 0-35 bar	STG140	↓		
		0-100 to 0-3000 psi/0-7 to 0-210 bar	STG170	↓		
		0-100 to 0-6000 psi/0-7 to 0-420 bar	STG180			↓
	In-Line	0-5 to 0-500 psi/0-0.34 to 0-35 bar	STG14L			↓
		0-100 to 0-3000 psi/0-7 to 0-210 bar	STG17L			↓
		0-100 to 0-6000 psi/0-7 to 0-420 bar	STG18L			↓
	0-200 to 0-10000 psi/0-14 to 0-690 bar	STG19L			↓	
Absolute Pressure	Single Head	0-50 to 0-780 mm HgA/0-67 to 0-1040 mbarA	STA122	↓		
		0-5 to 0-500 psi/0-0.34 to 0-35 bar absolute	STA140	↓		

**TABLE I - METER BODY**

Materials of Construction	Wetted Process Heads	Vent/Drain Valves **	Barrier Diaphragms				
	Carbon Steel *	-	316 LSS	A __	*	*	*
Carbon Steel *	-	Hastelloy C	B __	*	*	*	
Carbon Steel *	-	Monel	C __	*	*	*	
316 St. St.	-	316 LSS	E __	*	*	*	
***	-	316 LSS	E __				*
316 St. St.	-	Hastelloy C	F __	*	*	*	
***	-	Hastelloy C	F __				*
316 St. St.	-	Monel	G __	*	*	*	
Hastelloy C	-	Hastelloy C	J __	*	*	*	
Monel	-	Monel	L __	*	*	*	
Fill Fluid	Silicone DC200 ****			_ 1 _	*	*	*
	CTFE			_ 2 _	*	*	*
Process Head Configuration	9/16" - 18 Aminco 1/2 NPT (female)			_ _ A	*	*	*
				_ _ G	*	*	*

\* Carbon Steel heads are zinc-plated. Not recommended for water service due to hydrogen migration. Use Stainless Steel heads.  
 \*\* Vent/Drains are Teflon coated for lubricity.  
 \*\*\* STGIXL has 316 SS process interface.  
 \*\*\*\* If STA122 operating below 50mm HgA, see Figure 2 in Specification 34-ST-03-61 and contact Marketing Applications for a "Special" Silicone DC704 quote.

## Model Selection Guide, cont.

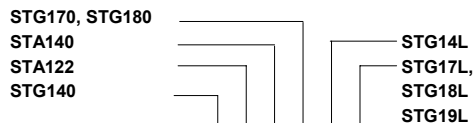


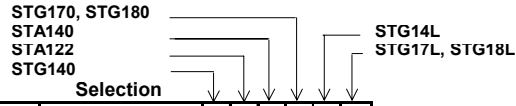
TABLE II	Selection	↓	↓	↓	↓	↓	↓
No Selection	00000	*	*	*	*	*	*

**TABLE III - OPTIONS**

None	00	*	*	*	*	*	*	
FOUNDATION Fieldbus Communications	FF	r	r	r	r	r	r	b
HART Protocol compatible electronics	HC	y	y	y	y	y	y	b
Analog Meter (0-100 Even 0-10 Square Root)	ME	*	*	*	*	*	*	b
Smart Meter	SM	*	*	*	*	*	*	
Customer Configuration of Smart Meter	CI	e	e	e	e	e	e	
Local Zero & Span	ZS	m			m	m	m	b
Local Zero	LZ	x			x	x	x	b
Lightning Protection	LP	*	*	*	*	*	*	
Custom Calibration and I.D. in Memory	CC	*	*	*	*	*	*	
Transmitter Configuration - non-Fieldbus	TC	*	*	*	*	*	*	
Write Protection	WP	*	*	*	*	*	*	
A286SS (NACE) Bolts and 302/304SS (NACE) Nuts for Head	CR	*	*	*	*	*	*	
Stainless Steel Customer Wired-On Tag (4 lines, 28 characters per line, customer supplied information)	TG	*	*	*	*	*	*	
Stainless Steel Customer Wired-On Tag (blank)	TB	*	*	*	*	*	*	
Modified DIN Process Heads - 316SS	DN	w	w	w	w			
Viton Process Head Gasket (Teflon is standard)	VT	z			z			
Mounting Bracket - Carbon Steel	MB	*	*	*	*	*	*	b
Mounting Bracket - ST. ST.	SB	*	*	*	*	*	*	b
Flat Mounting Bracket - Carbon Steel	FB	*	*	*	*	*	*	b
316 ST.ST. Electronics Housing - (with M20 Conduit Connections)	SH	n	n	n	n	n	n	b
1/2" NPT to M20 316SS Conduit Adapter (BASEEFA EEx d IIC)	A1	n	n	n	n	n	n	b
1/2" NPT to 3/4" NPT 316 SS Conduit Adapter	A2	u	u	u	u	u	u	
Stainless Steel Housing with M20 to 1/2" NPT 316 SS Conduit Adapter (use for FM and CSA Approvals)	A3	i	i	i	i	i	i	b
Clean Transmitter for Oxygen or Chlorine Service with Certificate	0X	h	h	h	h	h	h	
Over-Pressure Leak Test with F3392 Certificate	TP	*	*	*	*	*	*	
Calibration Test Report and Certificate of Conformance (F3399)	F1	*	*	*	*	*	*	b
Certificate of Conformance (F3391)	F3	*	*	*	*	*	*	b
Certificate of Origin (F0195)	F5	*	*	*	*	*	*	
FMEDA (SIL) Certificate	F6	*	*	*	*	*	*	
NACE Certificate (F0198)	F7	o	o	o	o	*	*	
Additional Warranty - 1 year	W1	*	*	*	*	*	*	b
Additional Warranty - 2 years	W2	*	*	*	*	*	*	b
Additional Warranty - 3 years	W3	*	*	*	*	*	*	b
Additional Warranty - 4 years	W4	*	*	*	*	*	*	b
Lifetime Warranty - 15 years	WL	*	*	*	*	*	*	b
High Accuracy	HA	*						

**Model Selection Guide, cont.**

Approval Body	Approval Type	Location or Classification	Selection						
No hazardous location approvals			9X	*	*	*	*	*	*
Factory Mutual	Explosion Proof	Class I, Div. 1, Groups A,B,C,D	1C	*	*	*	*	*	*
	Dust Ignition Proof	Class II, III Div. 1, Groups E,F,G		*	*	*	*	*	*
	Non-Incendive	Class I, Div. 2, Groups A,B,C,D		*	*	*	*	*	*
	Intrinsically Safe	Class I, II, III, Div. 1, Groups A,B,C,D,E,F,G		*	*	*	*	*	
CSA	Explosion Proof	Class I, Div. 1, Groups B,C,D	2J	*	*	*	*	*	*
	Dust Ignition Proof	Class II, III, Div. 1, Groups E,F,G		*	*	*	*	*	*
	Intrinsically Safe	Class I, II, III, Div. 1, Groups A,B,C,D,E,F,G		*	*	*	*	*	*
SA (Australia)	Intrinsically Safe	Ex ia IIC T4	4G	*	*	*	*	*	*
	Non-Sparking	Ex n IIC T6 (T4 with SM option)		*	*	*	*	*	*
ATEX*	Intrinsically Safe, Zone 0/1	Ex ia IIC T4, T5, T6	3S	*	*	*	*	*	*
	Flameproof, Zone 1	Ex d IIC T5, T6, Enclosure IP 66/67	3D	*	*	*	*	*	*
	Non-Sparking, Zone 2	Ex nA, IIC T6 (Honeywell), Enclosure IP 66/67	3N	*	*	*	*	*	*



\*See ATEX installation requirements in the ST 3000 User's Manual 97/23/EC Pressure Equipment Directive (PED)  
The ST 3000 pressure transmitters listed in this Model Selection Guide are in conformity with the essential requirements of the PED. A formal statement from TÜV Industry Service Group of TÜV America, Inc., a division of TÜV Süddeutschland, a Notified Body regarding the Pressure Equipment Directive, is available upon request

**TABLE IV**

Factory Identification	XXXX	*	*	*	*	*
------------------------	------	---	---	---	---	---

**RESTRICTIONS**

Restriction	Available Only With	Not Available With
Letter	Table Selection	Table Selection
a	Pending	
b	Select only one option from this group	
e	III SM	
h	_ 2 _	
i	III 1C or 2J	
m		III ME, FF
n		III 1C, 2J
o	III CR	
r		III TC, ME, 4G, 3S
u	III 1C, 2J	
w	I E _ G, F _ G, G _ G	
x	III FF, SM	
z		I B _ _ , F _ _ , J _ _
y		III 4G

**Note:** See ST-83 for Published Specials with pricing.  
See ST-89 and User's Manual for part numbers.  
See ST-OE-9 for OMS Order Entry Information including TC, manuals, certificates, drawings and SPINS.  
See ST-OD-1 for tagging, ID, Transmitter Configuration (TC) and calibration including factory default values.  
To request a quotation for a non-published "special", fax RFQ to Marketing Applications.

**Next Page Blank**



**Model Selection Guide, cont.**

This page intentionally blank

ST 3000® is a registered trademark of Honeywell International Inc.

HART\* is a trademark of the Hart Communication Foundation.

FOUNDATION™ is a trademark of the Fieldbus Foundation.

**Honeywell**

---

**Industrial Measurement and Control**

Honeywell International Inc.

16404 North Black Canyon Highway

Phoenix, Arizona 85053

©Honeywell International Inc.